

---

# GSM Operated Wireless Sensor Based Mine Security and Safety Approach

**Ganesh L. Borhade**

Department of E&TC Engineering  
Amrutvahini College of Engineering,  
Sangamner, India.

**Mahesh B. Kadu**

Department of E&TC Engineering  
Amrutvahini College of Engineering,  
Sangamner, India.

*Abstract—As of late, the incessant coal mine security mischances have brought on genuine obstructions and huge monetary misfortunes. It has given high essentials to avoid the underground complications within the mines with better improved in the mine security aspects. In this paper, GSM operated Wireless Sensor (WS) based mine security and safety methodology is presented. Different conditions within the mine have been considered including mine temperature, humidity, Oxygen monitoring, smoke and CO<sub>2</sub> levels and so on with control actions. All these conditions are monitored and controlled with the use of WS grids. Remote hubs are allotted for every sensor so that wireless data transmission alongside telemetry applications has been carried out.*

*Keywords—mine safety; mine security, wireless nodes and sensors, wireless sensor system.*

## I. INTRODUCTION

Mining is the conventional need to extract the mineral deposits for the ore so that various energy sources including fossil fuel, coal etcetera can be obtained. Various mining activities are carried out by the underground of the earth's surface to obtain the numerous minerals. Nowadays, industrializations have been spread worldwide in search of minerals and mining functions have been trending.

While mining, much manpower along with the mechanical equipments served for obtaining the minerals. The mine environment may bring about damage or cause death of workers in the mine due to human or environmental errors within the mine, arising the need of mine safety and security [1].

In previous days, one or more persons are allotted for carrying the messages within the number of sections of mine. They are used to go down inside the mine and report back with conveying the mine real-time situations at the head ends [2]. This method

was quite time consuming and straight forward so that serving the critical situations was not properly assisted. Later on in 1981, Leaky radio feeder system was proposed for coal mining based on RF systems. As mine areas are larger, they were using repeaters and two way communications has been brought in picture [2]. Leaky co-axial cable is used for transmission of VHF frequencies serving the wireless mobile stations. Further studies based on the earth's inter-environments were carried with the determination of earths stability-earthquake and other electromagnetics phenomenon [3]. Based on the earths magnetics filed variations and observations the analytical probabilistic framework is prepared and solutions are made available for mine safeties. The conventional hardwired based system was replaced by programmable logic controllers (PLC) to manipulate and integrate the safety levels within the mines. Probabilities of failure are depicted and automatically system reset conclusion being made to avoid the critical operations within the mines [4].

International Standard Organization (ISO) has published ISO 45001 Occupational health and safety standard for industrial solicitations. Best possible results in terms of safety and security are obtained by means of strategic planning and considerations [5]. Vibration and acoustics based mine safety was proposed in 2015 which detects and rage out the moving targets within the mines [6]. This approach uses RF-Radio links for acquisition of microphone sensors and speakers are used for reproduction of movements within the fields. Later, sensor-relay technology was developed for measuring the filed situations are they are routed over the networks of zigbee [7]-[8]. Using the sensor technology with zigbee, command prompt operations are only carried

out with small areas within the mine and cannot able to monitor globally.

To achieve the high degree of mobility within the mine and control globally, GSM based acquisition system for mine safety has been proposed and presented. Several mine encompassing parameters and circumstances are observed and controlled by utilizing ARM based stage with GSM network support. Proposed system consists of different actuated filed sensors equipped with ARM controller and manipulated by using GSM network as per mine conditions. Mine conditions in terms of temperature, relative humidity, Carbon dioxide and Methane levels, air flow within the tunnels of mine, smoke and fire perceptions are done and controlled all inclusive within the mine to achieve the highest level of safety and securities.

## II. SYSTEM DESIGN AND DETAILS

Proposed system comprises three main sub-sections including sensor section, processing section and GSM section located inside the mine. Sensor section contains different sensors located inside the mine and they are equipped with the processing sections.

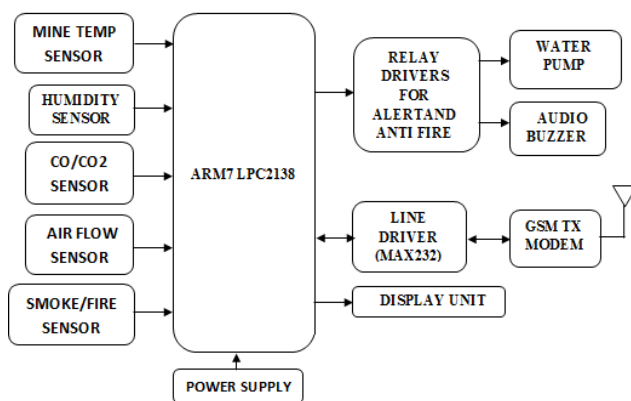

Fig. 1. Block diagram of sensor section of proposed system.

Acquisition of the perceived data from the sensors will be analyzed and administered towards the GSM section in order to transmit the manipulation actions from the supervisory control based Human to Machine Interface (HMI) system including computer coordination.

### A. Sensor Section

Block diagram of proposed mine security and safety system is shown in fig.1. It comprise of ARM-LPC 2138 controller as a hart of sensor section which

gives all the controlling stage to proposed framework by utilizing inputs sensors of temperature, humidity, CO<sub>2</sub>, airflow and smoke.

The GSM module (SIM 900) has actualized in the field condition to get to the constant varieties within the conditions of sensors. Sensor section consist of Temperature sensor (LM-35), Humidity sensor (HS230), CO/CO<sub>2</sub> sensor (MQ7), Smoke/Fire sensor (MQ6) and Air flow sensor (Anemometer)

### B. Control Section

Block diagram of control section is shown in fig. 2. It conveys detected parameters on LCD for investigation purpose behind parameters to be screen. A GSM module has been situated to impart and transmit the parameters between control section and sensor section.

Microcontroller joins got information towards the LCD show unit and again it is convey forward to clients cell phone by means of GSM system that has been actualized by GSM Module. Controller or supervisor can starts the controlled commands for mine parameters against the identified edges of thresholds.

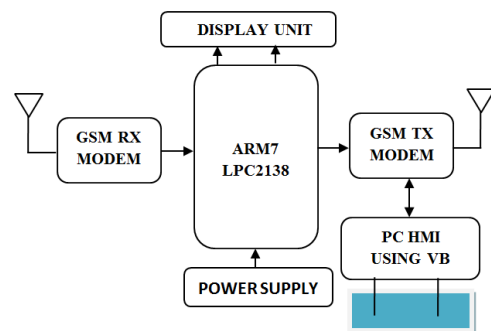

Fig.2. Block diagram of control section of proposed system.

Here the relay banks alongside drivers have been utilized to keep up the required conditions in mine if input parameter crosses the limits appointed to the controller.

## III. SYSTEM OPERATION

### A. Sensor Section Operation

The sensor section should have the ability to:

- Gather information of various parameters from the mine surrounding condition: Collect and gather the related various parameters including temperature, humidity, CO/CO<sub>2</sub> levels, airflow, fire and smoke

levels can be constantly checked and depend on varieties, the information ought to be gathered.

- Perform simple to computerized change on the gathered information:

As per gathered information, for appropriate signal molding, information must be changed over into the simple to computerized arrange (analog to digital conversion).

- Contrast the gathered information and limit information:

As per Predefined sensor condition the varieties from the gathered sensor information can be look at for serving the next operation.

- On the off chance that any parameter differs then make obliged move to control varied condition:

The variations with in the mine parameters can be served by utilizing control activities.

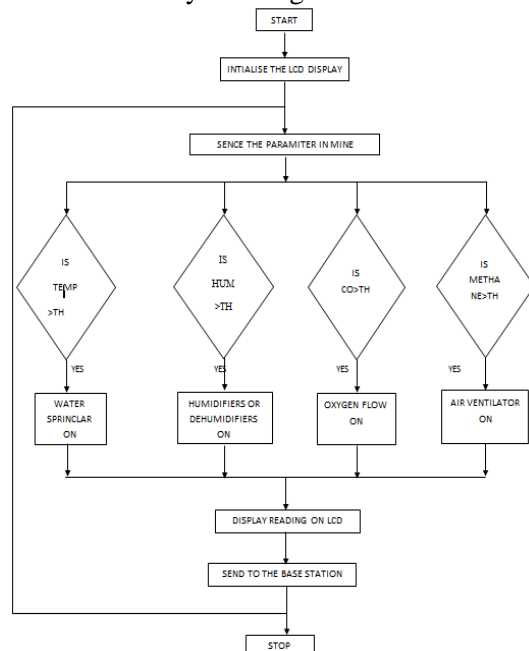

Fig. 3. flow chart for sensor section.

- Display the readout information over the display:

To show the gathered information by methods for measured representation of parameters.

- Send current status information to the base station:

Here we need to send the gathered information by sensor section to base section by utilizing GSM transmitting system.

Fig. 3 demonstrates the operational flow chart for sensor station.

### B. Operation of Control Section

The control section should have the ability to

- Get information from the sensor section:  
To receive the conveyed statistics by sensor section by using GSM transmitting technology form the mine.
- Send the obtained information packets to indication unit for representation of sensed data from the mine.
- Send the showed information to client by utilizing GSM Network as SMS.

## IV. RESULTS AND DISCUSSIONS

The proposed framework is simulated by utilizing protious hardware design tool and tentatively evaluated for different states of sensors within the mine environments. In this section of paper, functional readings from temperature sensor, humidity sensor, CO/CO2 sensor, fire and smoke sensor and so on are discovered. Every sensor on sensor station has watched for its ideal execution against characterized levels. The signal variations inside the allocated edge margined levels are analyzed for different sensors.

### A. Teperature Sensor Readings

Sensor considered for temperature measurement is LM35 with temperature set resolution of 50<sup>0</sup> C and analyzed concerning output device. Status of cooling system has been analyzed for addition and decrement of threshold edges of 50<sup>0</sup> C temperatures.

- If temperature is above 50<sup>0</sup>C, cooler systems should be turned ON which is shown in fig. 4.
- Temperature is less thanto 50<sup>0</sup>C, cooling system should be OFF state which is shown in fig. 5.
- Turn off the cooling system and show the message for time requires by cooling fan to maintain temperature less than 50<sup>0</sup>C.

Temperature sensor voltage relationship is shown in fig. 6.

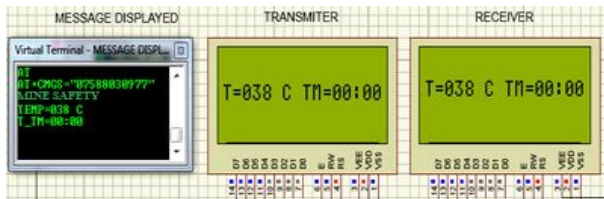

Fig. 4. Simulated results for temperature < 50°C.

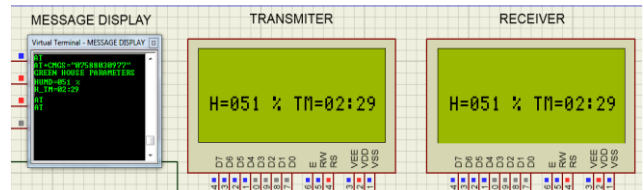

Fig. 8. Simulated Results for Humidity > 45%.

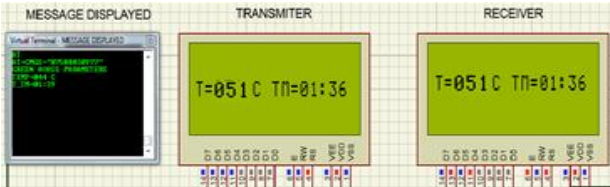

Fig. 5. Simulated results for temperature > 50°C.

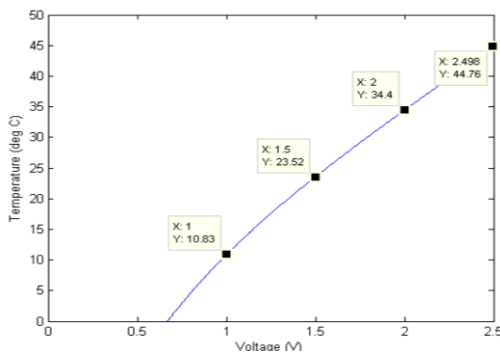

Fig. 6. Temperature sensor voltage relationship.

### B. Humidity Sensor Readings

Sensor considered for humidity measurement is HS230 with humidity level of 45%. Status of warmer for humidity system has been analyzed for addition and decrement of threshold edges of 45% of humidity within the mine.

- If Humidity is a lesser amount of 45%, warmer should be ON as shown in fig. 7.
- If Humidity is a more than of 45%, warmer should ON be as shown in fig. 8.
- Turn off the heating system and show the message for time requires by heater to maintain humidity less than 45%.

Humidity sensor voltage relationship is shown in fig. 6.

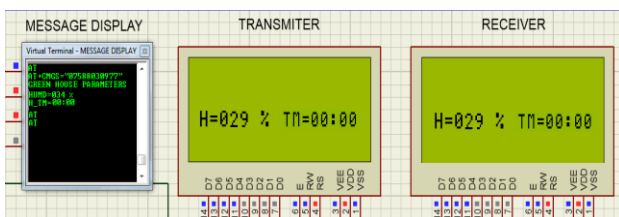

Fig. 7. Simulated result for humidity < 45%.

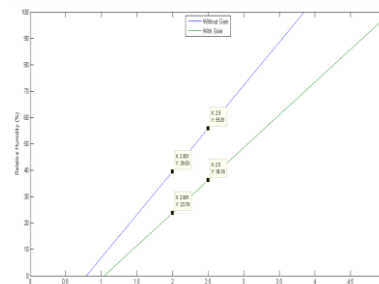

Fig. 9. Humidity sensor voltage relationship.

### C. CO/CO2 Sensor Readings

Sensor considered for CO/CO2 measurement is MQ-135 with density level of 30%. Status of oxygen present within the mine has been analyzed for addition and decrement of threshold edges of 30% of CO/CO2 within the mine.

- If density levels of CO/CO2 present in the mine is more than 40%, then oxygen tank should be opened as shown in fig. 10
- Whereas, the density level is less than 40% then oxygen tank should be closed and in freeze state as shown in fig. 11.
- Display the note of time required for maintaining oxygen tank open over the display and convey the same over the GSM modem.

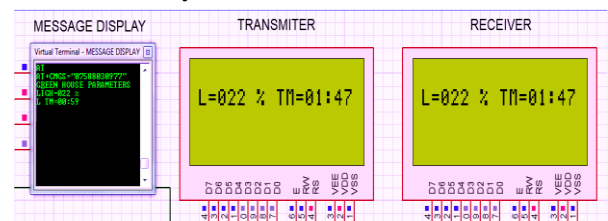

Fig. 10. Simulated results CO/CO2 levels < 40% of density.

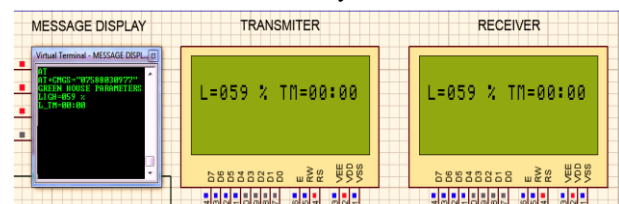

Fig. 8. Simulated results CO/CO2 levels > 40% of density.

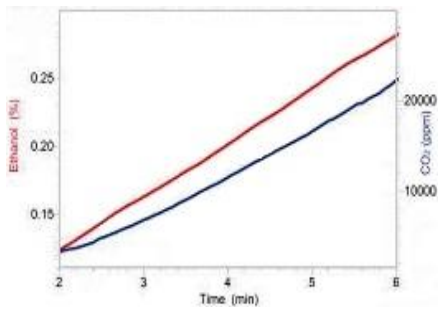

Fig.12.CO2 sensor voltage relationship.

**D. Airflow Sensor Readings**

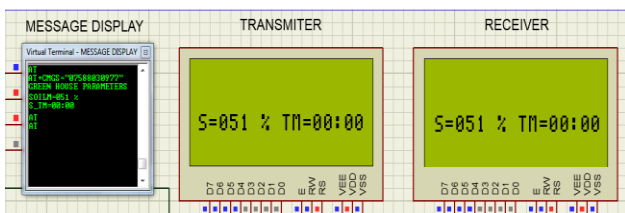

Fig. 12.Simulated results of airflow with anemometer RPM > 50.

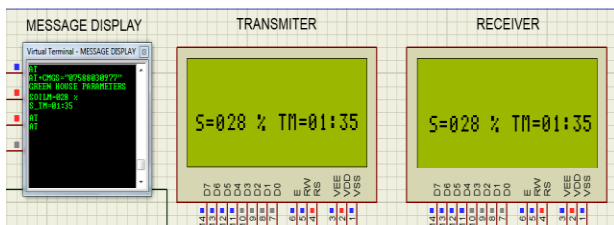

Fig. 13.Simulated results of airflow with anemometer RPM < 50.

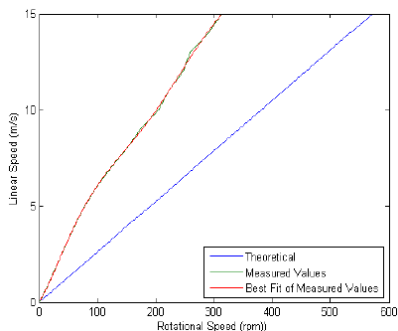

Fig.14.Optical switch OPB804 voltage relationship and read out.

For measurements of airflow within the mine, three cup anemometer is adopted. Optical switch OPB804 is adopted to calculate the response of air flowing through the mine. Ambient air flow is considered for 60 seconds of time and RPM of anemometer is displayed over the display.

- If airflow within the mine is more than 50 (RPM) which has been detected by optical

switch OPB804 then, fans within the mine will be OFF as shown in fig.12.

- If airflow is less beyond the 40 to 50 RPM then fans within the mine must be ON as shown in fig.13.
- Same information about the airflow is carried and conveyed out by using GSM modem to mine supervisor.

Sensor readouts by means of anemometer readings has been determined by optical switch driver OPB804 as shown in figure 14.

**E. Smoke and Fire Sensor Readings**

Smoke detector sensor of MQ-6 has been utilized with resolution resistance of 200 to 2000rpm and sensed output is represented as a time versus respective rpm resistance. Sensor readout is shown in fig. 15.

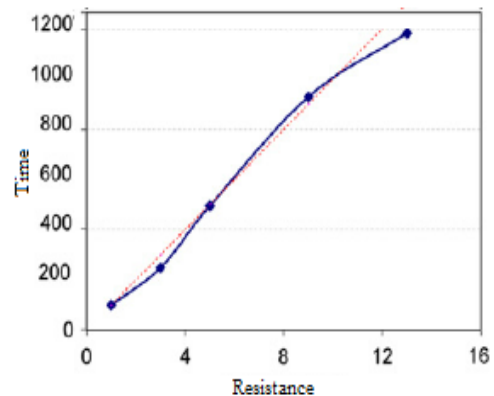

Fig.15.MQ-6 smoke/fire sensor voltage relationship.

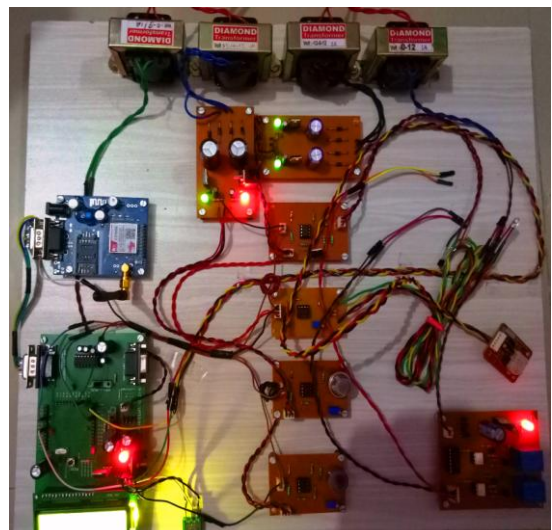

Fig.16.Photograph of fabricated project for GSM Operated Wireless Sensor Based Mine Security and Safety.

Complete project setup for mine safety and security is shown in fig. 16.

#### V. CONCLUSION

In this paper a complete mine security and safety framework and structure has been suggested. Proposed system is more conservative and modular, utilizing a mix of mechanical hardware along with electronic fittings in simulation environments. Estimations of distinctive mine parameters and control over them is showed including temperature, humidity, CO<sub>2</sub>, airflow and fire/smoke situations in the mine. In this system, GSM modem has been utilized for initiating the control actions from the mine supervisor to carry out the safety and security at the unexpected variations of mine parameters. Proposed system shows good remedy over the present systems for mine safety considerations.

#### REFERENCES

- [1] Thomas P. Pearson, "The Mine Safety and Health Administration and How It Affects the Synthetic Fuels Industry", IEEE Trans. on Industry Applications, vol. IA-19, no. 6, pp. 1024-130, December 1983.
- [2] Valdo Henriques and Reza Malekian, "Mine Safety System Using Wireless Sensor Network", IEEE Access, DOI: 10.1109/ACCESS.2016.2581844, pp. 3511-3521, July 22, 2016.
- [3] David J R Martin, "Cost-Effective Lfaky-Feeder Radio Systems", IEEE National Coal Board Transaction, pp. 137-141, November 1981.
- [4] John J. Sammarco, "Programmable Electronic and Hardwired Emergency Shutdown Systems: A Quantified Safety Analysis", IEEE Trans. on Industry Applications, vol. 43, no. 4, pp. 1061-1068, July 2007
- [5] Occupational Health and Safety ISO 45001 Handbook, Int. Org. Standardization, UK, 2016, Online available at: <http://www.msha.gov/REGS/ACT/MinerAct2006home.asp>
- [6] Reimar Pfeil, Markus Pichler, "Robust Acoustic Positioning for Safety Applications in Underground Mining", IEEE Trans. on Instrumentation and Measurement, DOI:10.1109/TIM.2015.2433631, pp. 1-13, March 2015.
- [7] Wei Ni, Iain B. Collings, "Relay-Assisted Wireless Communication Systems in Mining Vehicle Safety Applications". IEEE Trans. on Industrial Informatics, vol. 10, no. 1, pp. 615-627, February 2014.
- [8] N. Surendranath Reddy, Srinivasa Saketh M and Sourav Dhar, "Review of Sensor Technology for Mine Safety Monitoring Systems: A Holistic Approach", 2016 IEEE First International Conference on Control, Measurement and Instrumentation (CMI), pp.429-434, May 2016.